

Simba S7

Rugged rig with smart design and increased automation made for tight, tough conditions

The Epiroc logo, consisting of a stylized blue cube icon followed by the word "Epiroc" in a bold, sans-serif font.

Flexibility, versatility and reliability

Maximize productivity in small spaces with the Simba S7. This hydraulic long-hole drill rig is built for small spaces and tough drilling conditions. Increased automation lets you add the functionality you need to this versatile rig.

⊕ Main benefits

Highly maneuverable long-hole production drill rig suited for small to medium drift sizes due to its compact size

High versatility with Epiroc Rig Control System (RCS) that includes several automation features

Durable in tough conditions thanks to Epiroc's hydraulic top hammers

Front and rear mounted stingers for stable set up for drilling

Sturdy hydraulic boom concept enables stable set up of the drilling unit

Made for hard rock drilling, the COP1838+ and MUX+ are Epiroc's hydraulic top hammers, designed to excel in tough working conditions





The well-proven Epiroc Rig Control System (RCS) add-on increases automated functionality and lets you choose the level of automation you need to optimize your planning, monitoring and performance.



The hydraulic top hammers COP1838+ and MUX+ are made for hard rock drilling in tough conditions.



The control system includes options like ABC Regular, Extractor, Drill plan handling and Void detection to add even more value to your investment.

ROPS and FOPS certified cabin for a safe and comfortable operator environment

Breakthrough automatic stop, automatic parallel holding and tele-remote control are some of the optional automation features



Increased productivity improves profit

The Simba S-series is designed with the bottom line in mind. The result is rugged performance, flexible automation and improved safety all in one package. With its compact size, the Simba S-series is a highly maneuverable long-hole production drill rig suited for small to medium drift sizes.



+ Safety leads to success

Safer working conditions add value to your operations in the form of healthier personnel and decreased stoppages. Safety precautions like automatic drill stoppage prevents accidents involving both personnel and equipment. Add-on automation, including tele remote control, greatly improves the operator's work environment.



+ Automation ready

The automation ready Simba S7 gives you the power to continually upgrade your machinery with the functions you need. Enhance the overall productivity of your operations by allowing drilling through shift changes and breaks.



+ Customer based solutions

Epiroc strives to be the industry leader in automation technology and competence. Over the last 20 years we have refined our solutions via practical work experience and an on-going dialogue with partners and customers. Today, more than 3 000 RCS-equipped rigs are adding value and precision to mining and tunneling operations around the world.



A comprehensive service offering

Even the best equipment needs to be serviced regularly to make sure it sustains peak performance. An Epiroc service solution offers peace of mind, maximizing availability and performance throughout the lifetime of your equipment. We focus on safety, productivity and reliability.

By combining genuine parts and an Epiroc service from our certified technicians, we safeguard your productivity – wherever you are.

Drilling system

COP 1838+	○
COP 1838MUX+	○
Dry drilling system	○
Thread lubrication kit	○
Hole blowing kit (internal system with CE certified air reciever) Note: Not valid when using DCT.	●
Water mist flushing, external water and air supply (hydraulic oil cooled by water cooler)	○
Water mist flushing, external water and air supply (hydraulic oil cooled by air fan)	○
Rock drill lubrication warning kit	●
Drill stop*	○

*Mandatory for CE

Boom/drilling unit

BUT 32PD	●
Rod Handling System, RHS 10 (10+1 rods) mechanized drilling up to 20 m*	●
Adaptable to 3, 4, 5' and 6' rods	●
Adaptable to R32, T38, T45 drill rods	●
1 x rear and 1 x front stinger	●
Automatic lubrication for drilling and positioning unit	●

*3' rods gives 12 + 1 rods in the carousel

*T45 speed rods gives 9+1 rods in the carousel. Denna text behöver också vara med i kombination till den du lade till.

Feed

Feed type	Intended for rock drill	Rod/tube length mm	Total length mm
BMHP 6803	COP 1838ME	915	2 731
BMHP 6804	COP 1838ME	1 220	3 035
BMHP 6805	COP 1838ME	1 525	3 340
BMHP 6806	COP 1838ME	1 830	3 645
BMHP 6803X	COP 1838MUX	915	2 933
BMHP 6804X	COP 1838MUX	1 220	3 237
BMHP 6805X	COP 1838MUX	1 525	3 542
BMHP 6806X	COP 1838MUX	1 830	3 847

Air system/water system

Air flow guard	●
Compressor: Epiroc LE7	●
Compressor GAR 30	○
Hydraulic water booster pump, max capacity at 12 bar boost 60 l/min. Minimum water inlet 2 bar	●
Water hose reel including hose	○

Electrical system

Total installed power 80 kW (main motors 1x75 kW)	●
Voltage 380-1 000 V 50/60 Hz	●
Starting method star/delta (400-690 V)	●
Starting method - soft start (not for 1 000 V)	○
Electronic overload protection for electric motors	●
Digital voltmeter/amperage meter in electric cabinet	●
Switch gear	○
PC4 or PC5 plug/socket	○
Phase sequence and earth fault indicator	●
Battery charger	●
Stainless steel electrical enclosure	○

Hydraulic system

Low oil level indicator	●
Oil temperature gauge on oil tank	●
Water/oil cooler in stainless steel	●
Filtration 16 µm	●
Oil filter indicator	●
Mineral hydraulic oil	●
Electrical oil filling pump	●
Heater kit for hydraulic oil tank	○
Biodegradable hydraulic oil	○
Ni-Cr plated piston rods (limited selection on request)	○

Drifter rods/pipes

Rock drill	Rod/Pipe	Guide tubes	Hole diameter (mm)
COP 1838+	R32 Speedrod	N/A	51-64
COP 1838+ MUX+	T38 Speedrod	TDS 56	64-76
COP 1838+ MUX+	T45 Speedrod*	TDS 64	70-89

Carrier

Deutz BF4 L 914, 72kW Stage II/Tier 2	○
Deutz D914 L04, 55kW Stage IIIA/Tier 3	○
Deutz TD 3.6 L04, 55kW Stage IIIB/Tier 4i	○
Front axle DANA Spicer 123/90	○
Rear axle DANA Spicer 123/90 ±8° oscillation	○
Articulated steering ±40° steering angle	●
Four-wheel drive	●
Electric system 24 V	●
Batteries 2x12 V, 70 Ah	●
Automatic differential lock on front axle, limited slip	●
Tires 9.00 x R20	●
Tramming lights 6x40 W LED, 2x80 W, 24 V DC	●
Working lights 4x80 W LED, 24 V DC	●
Illuminated stairs for platform LED	●
Front and rear jacks	●
Fuel tank, volume 60 l	●
Fire suppression system ANSUL (manual, checkfire or automatic)	○
Rig washing kit*	○
Manual lubrication kit	○
Boot washing kit*	○

*Not applicable when equipped with dry drilling system

Cabin (optional)

ROPS and FOPS certified cabin, noise level <80 dB(A)	●
Swingable seat for drilling and tramming	●
Front window 22 mm (P8B safety classified)	●
12 V outlet	●
Mediaplayer	○
Air condition	●
Electrical heater, 1.2 kW, 230 V (CE)	○
Manual spotlight 70 W (left and right)	○

Protective roof

FOPS certified	●
Stainless steel	○
Manual spotlight 70 W (left and right)	○
Swingable seat for drilling and tramming	○

Recommended cable size and length

Voltage	Type	Dimension (mm ²)	Diameter (mm)	Length (m)
380-525 V	Buflex	3x70+3G16+2x1.5	37	110
550-575 V	Buflex	3x50+3G6+2x1.5	32	150
660-690 V	Buflex	3x35+3G6+2x1.5	28	200
1 000 V	Buflex	3x35+3G6+2x1.5	28	200

Recommendations are given for surrounding temperature of 40 °C and up to a height of 2 000 m

Control system

Direct Control System (DCS)	○
Epiroc Rig Control System (RCS)	○
Angle Reading Instrument (ARI)	○
Angle Reading Instrument (ARI) with hole depth measurement	○
Breakthrough automatic stop	○
Underground manager pro	○
Drill plan handling	○
Void detection	○
Automatic parallel holding	○
Rig Remote Access (RRA)	○
Mobile tele remote/multi tele remote	○
Remote operating kit	○
Remote controlled camera on tripod with monitor in cabin	○
Total station navigation	○

Dimensions

Measurement	
Width	2 100 mm
Height tramming, roof up/down	2 800/2 100 mm
Length tramming (with BMHP 6 804/05/06)	9 300/9 600/9 900* mm
Ground clearance	365 mm
Turning radius outer/inner	5 000/2 850 mm

*+200 mm with extractor

Gross weight (depending on configuration)

Total	13 500 kg
Boom side	9 000 kg
Engine side	4 500 kg

Tramming speed

On flat ground (rolling resistance 0.05)	>15 km/h
On incline 1:8	>5 km/h

Noise and vibration

Operator sound pressure level in canopy, drilling, free field (ISO 11201)	106±6 dB(A) re 20 uPa
Operator sound pressure level in cabin, drilling, free field (ISO 11201)	75±3 dB(A) re 20 uPa
Operator sound pressure level working close to machine, drilling, free field	106±6 dB(A) re 20 uPa
Sound power level (ISO 3744), drilling, free field	126 dB(A) re 1pW
Vibration levels seated, drilling (ISO 2631-1) cabin	0.07±0.07 m/s ²
Vibration levels standing, drilling (ISO 2631-1) cabin	0.07±0.07 m/s ²
Vibration levels seated, drilling (ISO 2631-1) canopy	0.1±0.15 m/s ²
Vibration levels standing, drilling (ISO 2631-1) canopy	0.1±0.15 m/s ²



Technical specifications

Dimensions in millimeters

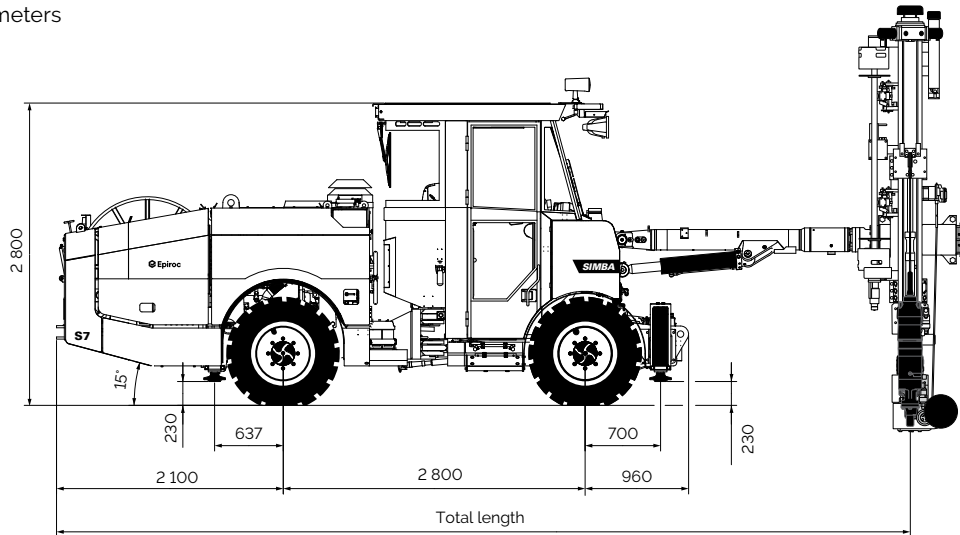

Sideview.

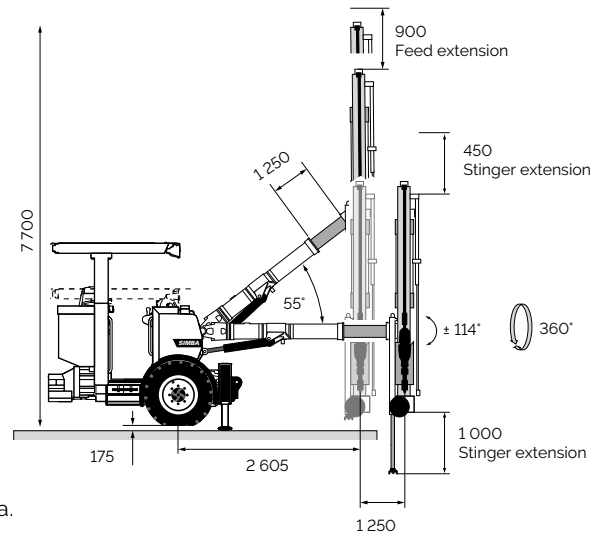

Coverage area.

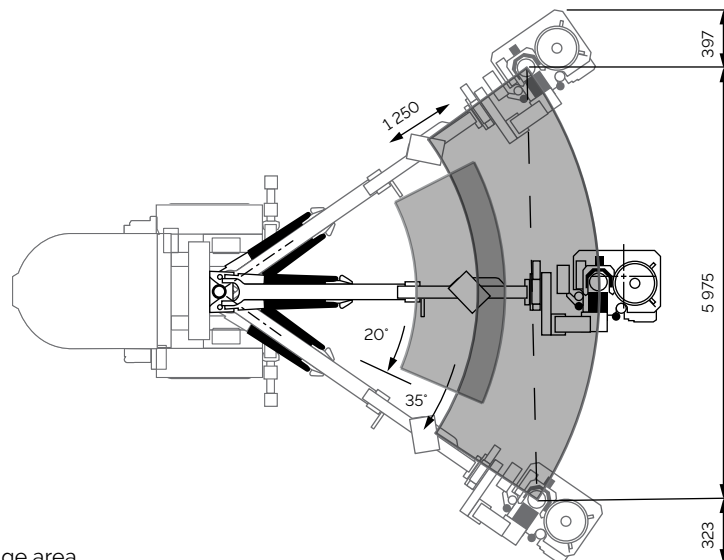

Coverage area.

United in performance. Inspired by innovation.

Performance unites us, innovation inspires us, and commitment drives us to keep moving forward. Count on Epiroc to deliver the solutions you need to succeed today and the technology to lead tomorrow.
epiroc.com

